

Vactor Full-sized HXX HydroExcavator



The Right Choice for the Big Digs



Safe

The Vactor HXX HydroExcavator is a powerful machine that can tackle major excavations while still providing safe, non-destructive digging you associate with vacuum excavation.

You can use your HXX HydroExcavator for large excavation projects or high-precision slot trenching.

Smart

The HXX HydroExcavator is highly productive.

- Multi-flow pump system allows you to adjust water pressure with a turn of the knob for digging in various conditions.
- 320-degree rotating boom with telescopic option maximizes work area.
- Large, 12 yd³ capacity, corrosion- and abrasion-resistant steel debris tank with 50-degree dump body facilitates fast removal of large amounts of material.
- 1,300-gallon stainless-steel water tank provides hours of productive digging, while single-cell tank design protects against freezing.
- Optional 425,000 BTU or 900,000 BTU water heater helps cut through frozen ground and clay.
- Optional cold weather package which includes a heated pump and hose-reel cabinet to protect against winter weather.
- Dual hydraulic cylinders open a three-quarter rear door; hydraulic four-point locking mechanism ensures a tight seal when closed.
- User-friendly and ergonomically designed control box is located curbside for easy access and efficient operation.

As with any Vactor machine, you can customize your HXX with a variety of options.

Reliable

The powerful, hardworking full-sized HXX HydroExcavator comes to you from Vactor, the most trusted name in air conveyance and water and vacuum technology. Our HXX HydroExcavators feature the productive know-how that comes from nearly 50 years of supplying contractors and municipalities with durable, reliable sewer and catch-basin cleaners—in a machine purpose-built for vacuum excavation.

VACTOR®
HXX™
VACUUM EXCAVATORS

For a demonstration or more information, contact:

Vactor Manufacturing
1621 S. Illinois St. Streator, IL 61364
815/672-3171 Fax: 815/672-2779
www.vactor.com

©2007 Federal Signal Corporation.
Some items shown may be optional. Specifications subject to change without notice.

Full-Sized Vactor HXX HydroExcavator

Available in Fan or PD Versions

Specifications

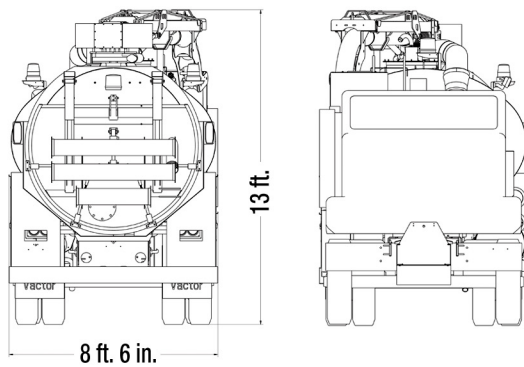
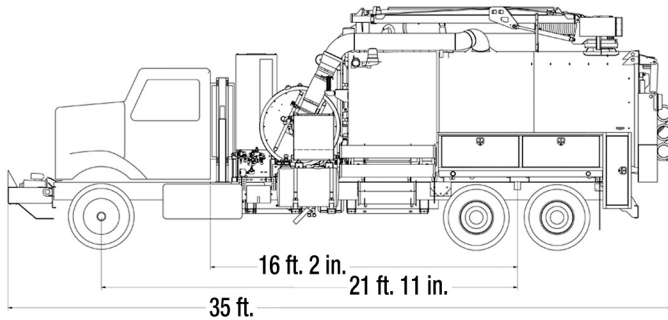

VACTOR®
HXX™
VACUUM EXCAVATORS

Debris Body

12 cu yd volumetric debris body
1/4 inch round design, abrasion and corrosion resistant Ex-Ten steel
Flat style, 3/4 rear door, hinged at top with replaceable neoprene seal
Hydraulic rear door open, close, and locking system
Front mounted hydraulic dump cylinder, 50 degree dump angle, power up / power down
Dual air ports with dual 10 inch stainless steel float ball shut off system / stainless steel screens

Water Tanks

1300 gal capacity
#304 3/16 inch stainless steel water tank
Anti-siphon device and anti-splash valve with 25 ft water fill hose and connectors
Water-level sight gauge
10-yr warranty against corrosion and cracking

Water System

Water system is design rated at 10 gpm @ 2500 psi
Hydraulically operated triplex piston water pump
Handgun hose 3/8 inch x 75 ft with operating pressure of 3500 psi and burst pressure of 14,500 psi

FAN Vacuum System

Dual 38 inch aluminum two-stage centrifugal compressor / fan system
Hydrostatic fan drive system
Vacuum relief located at the inlet of debris tank to allow operator to vent to atmosphere

PD Vacuum System

Hibon 8702 Tri-Lobe (28 inch Hg) 5250 cfm @ max. speed 2000 rpm
Ultra-quiet inlet and outlet silencers acoustically matched to blower
Direct drive OMSI transfer case
Vacuum relief located at the inlet of debris tank to allow operator to vent to atmosphere

Boom & Vacuum Hose

7 ft hydraulic extendable boom, top mounted, with 320 degrees of rotation
22 ft reach from the centerline of truck

Hydraulic System

FAN: Hydraulic reservoir capacity of 65 gal with strainers on all suction lines
PD: Hydraulic reservoir capacity of 50 gal with strainers on all suction lines
Oil-level sight gauge
Inspection hatch for maintenance
10 micron spin-on type filter

Electrical

Entire system will be moisture and vapor sealed
Electrical connections require no exposed wires or terminals
Light bulbs will be shock mounted

Paint

All metal surfaces shot blasted prior to painting
All metal surfaces will be phosphate washed prior to painting
Module components will be painted prior to assembly

Options

15 cu yd volumetric capacity debris body
Cold-weather package
7 ft hydraulic telescopic boom with 320 degree rotation
Wireless remote
Air purge system utilizing chassis air system
Water heater - 425,000 BTU / hr
Water heater - 900,000 BTU / hr (includes inverter, and chassis must have minimum 160 amp alternator)
20 gpm water pump
Hydraulic tool package
Second operator station
Additional toolboxes