

Broom Badger®



ELGIN
Subsidiary of Federal Signal Corporation



EASY TO OPERATE. EASY TO MAINTAIN. NO CDL REQUIRED

Looking for a maneuverable, powerful, compact mechanical sweeper? Consider the Broom Badger from Elgin Sweeper. This compact dual-engine sweeper is easy to operate and maintain, and does not require a CDL to operate, making it ideal for municipalities and contractors who need reliable, powerful cleaning without a full-size sweeper. The low-profile design uses best-in-class components, has reduced operating weight, and consumes less fuel than older equipment. The short wheelbase and tight turning radius give the operator great maneuverability for cul-de-sac curb lines and winding streets.





EASY OPERATION AND SERVICING MAKE BROOM BADGER AN EASY CHOICE

Even the best equipment is only as good as an operator's ability to master it. That is why the Broom Badger is engineered with ease of operation in mind.

It begins with a comfortable, quiet cab matched with outstanding maneuverability that includes a tight turning radius for precise sweeping performance and variable dump height for optimal material handling. To minimize downtime, the Broom Badger offers easy access to all key service points. Its many advantages include:

- Non-CDL; 19,500 lb GVWR chassis
- Left side variable high dump hopper configuration
- Compact wheelbase while offering powerful sweeping performance
- A 4 yd³ hopper, with optional LifeLiner greatly improves the life, durability and functionality of the hopper.
- Dual 42" side brooms create a 10' wide sweeping path.



EXCLUSIVE MEMORY SWEEP® DRIVES PRODUCTIVITY EVEN HIGHER

To enhance operator performance and reduce fatigue, this unique feature allows the operator to resume all previous sweeper setting with one touch control. It incorporates a multi-screen display highlighting engine hours and water level, as well as system diagnostics and optional broom features.



SUPERIOR MECHANICAL SWEEPER DESIGN

The Broom Badger is mounted on a 19,500 lb. GVWR Class 5 cab-over chassis with air ride suspension for operator comfort and highway travel speed for quick transport. The cab-over design provides excellent visibility and has a short 109" wheelbase and tight 16'9" turning radius for exceptional maneuverability. Spot mirrors and low-cut windows enable broad gutter broom viewing. A standard dual-camera and color monitor system provide additional views for increased safety when sweeping.

HIGH PRODUCTIVITY SWEEP SYSTEM

- Efficient Kubota 65 HP T4 Final engine
- Variable speed main broom and squeegee
- Robust and efficient hydraulic system
- Easy access to all components
- Only 6 grease points on sweeper body
- All pivot points feature chrome shafts with greaseless, long life bushings
- Adjustable conveyor speed with auxiliary engine RPM
- Optional LifeLiner system for the hopper



A SIMPLER DESIGN MEANS GREAT SAVINGS FOR YOU

ROBUST SIDE BROOMS

The Broom Badger features large dual side brooms with a maximum 10' sweep path. The direct drive brooms are controlled in-cab for down pressure and tilt angle. The trailing arm design with spring kickback protects them from damage when sweeping close to obstacles. Four solid steel arms on each broom feature chrome shafts with composite greaseless bushings on all pivot points. These bushings reduce daily maintenance and have a long lifespan that results in lower overall operating costs.

EFFICIENT MAIN BROOM

The 58" polypropylene main broom is hydraulically driven. The elevator is slightly wider for close broom placement, providing more efficient material lifting and maximizing broom effectiveness. Self-aligning bearings for the broom mount and the free floating design ensure smooth movement over road surfaces. Simple adjustments for down pressure can be made to prevent broom coning.

LARGE DEBRIS HOPPER

The side-dumping, 4 cubic yard debris hopper allows extended sweeping intervals for increased productivity on the job. The hopper is lifted by a single 2 stage scissor lift with 9,400 lb lift capacity. A full payload can be off-loaded from the side dump hopper at ground level or at dump heights up to 10 feet.

Broom Badger®

INNOVATION AT WORK

A closer look at the Elgin Broom Badger reveals innovative design features, systems, and components that not only simplify operation and improve performance but also make maintenance and servicing faster and easier. The result is the optimal efficiency of your operations, as you reduce maintenance requirements and downtime. The Broom Badger brings you an array of innovative systems including:



HEAVY DUTY SQUEEGEE ELEVATOR

The Broom Badger's wide direct drive squeegee elevator handles heavy-duty sweeping applications. The updated design borrows elements from Elgin's family of mechanical sweepers and delivers quieter operation in and out of the cab. For easy servicing and upkeep, the elevator cover opens wider for clean out. Due to the updated hydraulic system, the speed of squeegee elevator is now easily adjustable based on the auxiliary engine RPM in the truck cab. This allows an operator to quickly and easily adjust to varying debris conditions.



HYDRAULIC SYSTEM

Innovation on the Broom Badger can be found in the hydraulic system as well. The resulting system uses robust gear pumps to that reduce waste across the system meaning the auxiliary engine can run at lower RPMs. Cartridge valves are used throughout, yielding a durable and easy to maintain system. In cab electrical controls, external filter and restriction indicators, and low oil level shut-down are standard. All hydraulic valves are located in one ground level area for easy maintenance.



ELECTRICAL SYSTEM

The Broom Badger's simple electrical system has been carefully designed to be extremely easy to navigate. It is hard wired with no controllers and all electrical controls are sealed in a weather-proof systems locker. Wires are hot stamped with functions identified for easy trouble shooting.

OUR COMMITMENT TO QUALITY ONLY BEGINS WITH OUR EQUIPMENT

The Elgin Broom Badger is manufactured in an ISO 9001 certified, advanced industrial plant. We employ the latest technology to build the most reliable equipment, including high-precision laser cutters, efficient, accurate computer numerical controls, and a sophisticated powder coating system.

When you build a quality product you can back it up with a full one-year, unlimited hours warranty. Elgin also backs up your investment with superior local service and support. Our goal is to keep your machine—and your entire operation—up and running.

The Broom Badger can be customized to your unique requirements to meet local standards and regulations by means of a broad selection of configurations, options and accessories.

Through our international dealer network, we maintain a vast inventory of spare parts and offer fast shipment to any region of the world.

Altogether, the rugged, reliable Elgin Broom Badger is easy to operate, easy to maintain, and an easy choice when you are looking for quality equipment that is built to last.

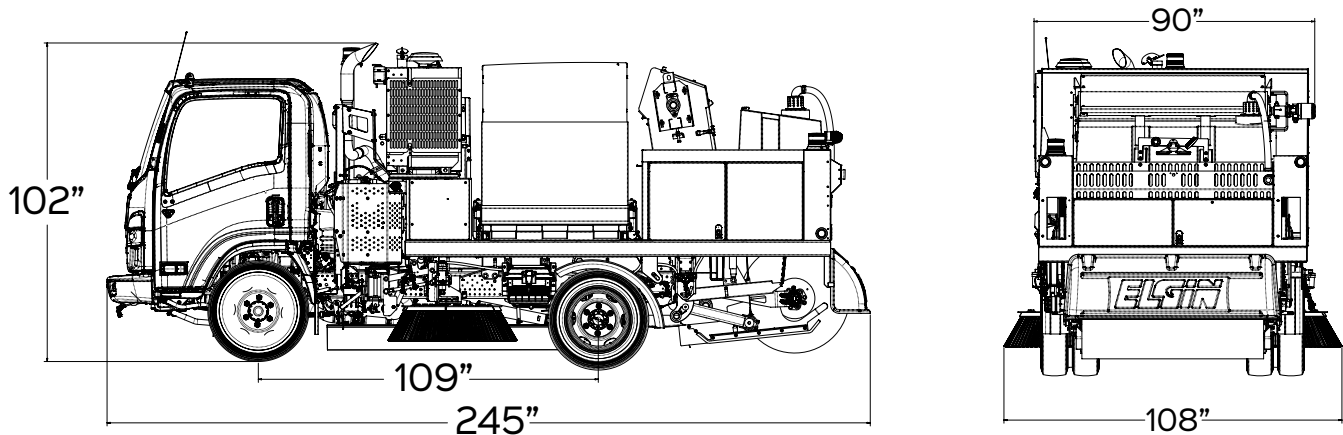

Broom Badger Truck Mounted Mechanical Sweeper Specifications

Sweep Engine	Hydraulic System	Dust Control System	Sweep System	Hopper
<p>Make: Kubota V2403-CR-TE4</p> <p>Type: 4 cylinder, vertical</p> <p>Displacement: 2.4 L</p> <p>Horsepower: 65 @ 2700 RPM</p>	<p>Sweep system pump: Triple section gear pump</p> <p>Capacity: 31 GPM @ 2400 RPM</p> <p>Reservoir capacity: 30 gal (114 L)</p> <p>Return filter: 10 micron</p> <p>Cooler: Externally mounted</p> <p>Valves: Electro-hydraulic with manual override</p>	<p>Tank: Polyethylene</p> <p>Tank capacity: 220 gals (833 L)</p> <p>Pump: Electric diaphragm</p> <p>Spray nozzles: 4 across main broom 3 over each gutter broom 5 across front bumper</p>	<p>Main broom: 58" (1,473mm)</p> <p>Sweeping path with 2 side brooms: 10' (3,048 mm)</p> <p>Side brooms: 42" (1,067 mm)</p>	<p>Capacity: 4 yd³ (3 m³)</p> <p>Hopper Lift and Dump Controls: Hydraulic in-cab</p> <p>Offload: Left Side</p> <p>Minimum dump height: 18" (457 mm)</p> <p>Maximum dump height: 10' (3,048 mm)</p>

Broom Badger[®]

**POWERFUL
VERSATILE
SIMPLY BETTER**

The Elgin Broom Badger street sweeper is easy to maneuver and does not require a CDL license to operate, making it an easy choice for any fleet.

FEATURES:

- Large 4 yd³ debris hopper
- Heavy duty squeegee elevator
- Robust triple section gear pump
- 10' sweep path
- 10' dump height



Elgin Sweeper • 1300 West Bartlett Road, Illinois 60120 USA
Phone 847-741-5370 | Parts & Service 877-800-1111

Specifications subject to change without notice. Some products shown with optional equipment. Elgin[®] is a registered trademarks of Elgin Sweeper.

Products may be covered by one or more United States Patents and/or pending patent applications.

Elgin Sweeper is a subsidiary of Federal Signal Corp. | Federal Signal Corp. is listed in the NYSE by the symbol FSS.
Effective Date 6/22 P/N 0705391-E ©2022 Elgin Sweeper Printed in the USA