

# 550 JET VAC

## TRAILER DIMENSIONS

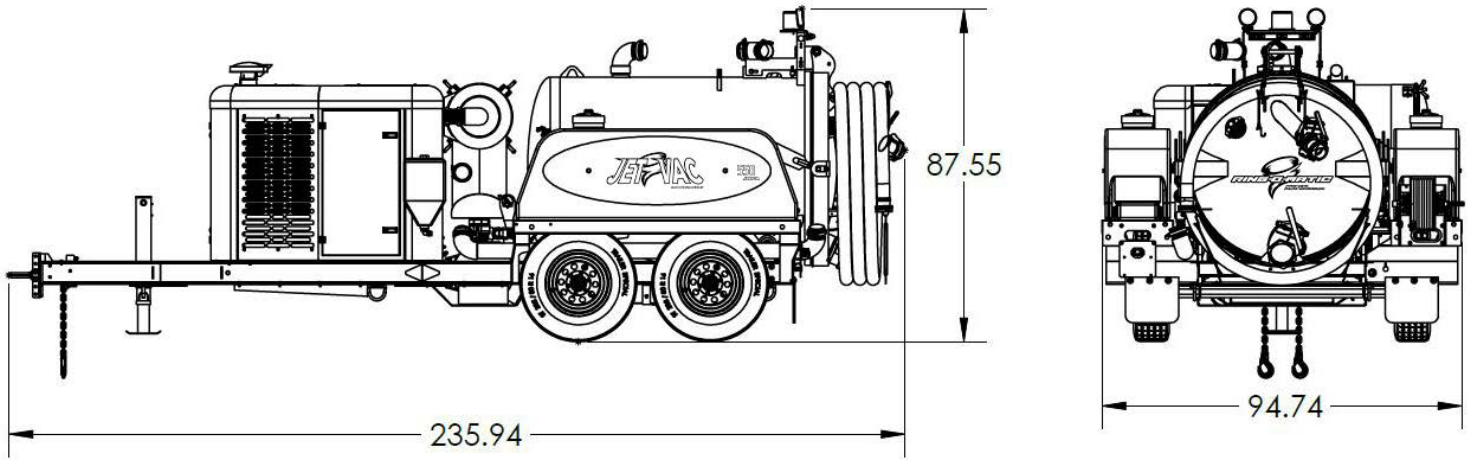

**FOR ALL TRUCK MOUNT  
SPECIFICATIONS PLEASE  
CONTACT OUR SALES  
DEPARTMENT @  
800-544-2518**



**1714 FIFIELD ROAD  
PELLA, IOWA 50219**

All equipment shown is for illustrative purposes only and may display optional accessories or components. Please contact your local Ring-O-Matic dealer or Corporate sales team for more information about machine specifications. Ring-O-Matic reserves the right to make changes in engineering, design and specifications; add improvements; or discontinue manufacturing at any time without notice or obligation. RING-O-MATIC, RING-O-MATIC Corporate logo, Ring-O-Matic Company R logo, PROVEN PERFORMANCE, VIPER and VLX are trademarks of Ring-O-Matic, INC. in the U.S. and / or other countries.





# 550 JET VAC

from the industry-leading innovator



[RING-O-MATIC.COM](http://RING-O-MATIC.COM)



# JET VAC

BY RING-O-MATIC



FEATURES	550 JET VAC
Mountings	Trailer
Spoils Capacity (gallons / liters)	550 gallons / 2,082 liters
Water Capacity (gallons / liters)	2 x 100 gallons / 2 x 378 liters
Optimum & Balanced Tongue Weight	1,000 lbs
Engine	Tier 4F Industrial Diesel
Fuel Tank Capacity (gallons / liters)	29 gallons / 110 liters
Dual LED work lights and strobe	Standard
Warranty	One Year

OPERATOR CONTROLS	
Controls Location	Front curbside with lockable cabinet
Hour Meter / Tachometer / Vacuum Gauge	Standard
Water Supply Reel	Rear Curbside
Load Level Indicator and Auto Shutoff	Sight Glass & Auto Shutoff
Reverse Flow	Standard

SPOILS TANK DETAILS	
Hydraulic Hoist Unload	Twin cylinder
Full Opening Rear Door	Hydraulically operated
Rear Door Latch	Power door lock
Inlet Valve Size / Drain Valve Size	4" / 6"

TRAILER DETAILS - HEAVY DUTY 6" C-CHANNEL FRAME	
Trailer/Hitch Type	Tandem Axle / Pintle
Height x Length x Width (feet / inches)	88" x 19'6" x 95"
Height w/ Boom	111"
Empty Weight - lbs / kg	7,140 lbs / 2812 kg
Gross Vehicle Weight Rating (lbs / kg)	13,000 lbs / 5898 kg
Axles, Capacity and Suspension Type	2 x 7,000 lbs axles on 165 gal
Tire Size	ST235/80 R 16 Load Range E
Trailer Brakes	Never adjust electric

VACUUM PUMP / BLOWER DETAILS	
Vacuum Pump/Blower Type	Positive displacement lobe pump
CFM / Max Hg	600 CFM / 15" or 1,000 CFM / 15"
Reverse Flow	Standard
Cyclo-Separator Air Filter Type / Capacity	Cyclo-Separator with 3 micron filter, 16,750 sq in capacity

WATER SYSTEM DETAILS	
Water Pressure / Water Supply	4,000 psi *factory set @ 3,500 psi / 6 gpm
Electronic Low Water Shut-Off	Standard
Auto Water Pump Unloader to Reduce Engine Loading & Wear	Standard
Water Pump Drive	Belt w/ Electric Clutch
Water Supply Hose	50' x 3/8" ID
Water Supply Reel Location	Rear, curbside
Easy-to-Use Winterize System	Standard

OPTIONS	
Cyclo-Jet Pothole Excavator	Recommended
Curbside Remote Auxiliary Hydraulics	Optional
Full Hydraulic Remote Controlled Boom or Manual Boom	Optional
Lighted Arrow Bar to Direct Traffic	Optional
Removable Water Heater	Optional
4" Vac Hose	Optional
In Tank Clean Out System	Optional
Sewer Jetter	Optional
2 x 165 Gallon Water Tanks	Optional

# KEY FEATURES

## ADVANCED AIR FILTRATION



Protecting the positive displacement blower is a key part of extending the life of your Jet Vac. A cyclonic pre-filtration into a 3 micron washable reusable filter media, provides the protection you need when vac'ing wet or dry materials.

## NOISE REDUCTION

When you work in populated areas, reducing noise is important. Standard on the Jet Vac you will find sound dampening material lining the inside of the power pack. Combined with a premium silencer, the most productive machine on the market has now become the quietest.



## ON-BOARD WATER



Streamlined water tanks provide you with 200-gallon of on-board water capacity, designed to keep the Center of Gravity low and well positioned over the axles to maximize tow-ability. Low water shutdown is standard to assist in eliminating the chance of running the water pump dry. Also Available are 2/165 gallon water tanks.

## TRAILERING / AXLES

Torsion flex low profile axles come standard on all Ring-O-Matic trailer units. Reduced maintenance and enhanced towing over rough grade and on the highway, make these axles the premium choice.



## OPERATOR CONTROLS



Weather protected, lockable recessed control panel eliminates the opportunity for vandalism and damage due to exposure to the elements. Integrated into the power pack also allows us to reduce wire harness and connectors to help in improving reliability. The control panel is behind a lockable door that is within an access door to key components within the power pack.



## CLEANEST. SAFEST. FASTEST. EASIEST. ONE MAN POTHOLING SOLUTION.

ONLY AVAILABLE FROM RING-O-MATIC, THE VIPER POT HOLE TOOL DELIVERS UNMATCHED PERFORMANCE ON THE JOB SITE.

THE VIPER DELIVERS INCREASED PROFITABILITY AND PRODUCTIVITY FOR CONTRACTORS, MUNICIPALITIES, OWNERS/ OPERATORS, AND RENTAL OPERATIONS. CONCERNED ABOUT JOB SITE SAFETY? THE VIPER PROVIDES SAFE EXPOSURE/ DAYLIGHTING OF UTILITIES AND IN OPERATOR SAFETY VIA THE DIELECTRIC FITTING. THERE'S NO OTHER TOOL LIKE IT ON THE MARKET.



800.544.2518