

850 VX

SKID DIMENSIONS

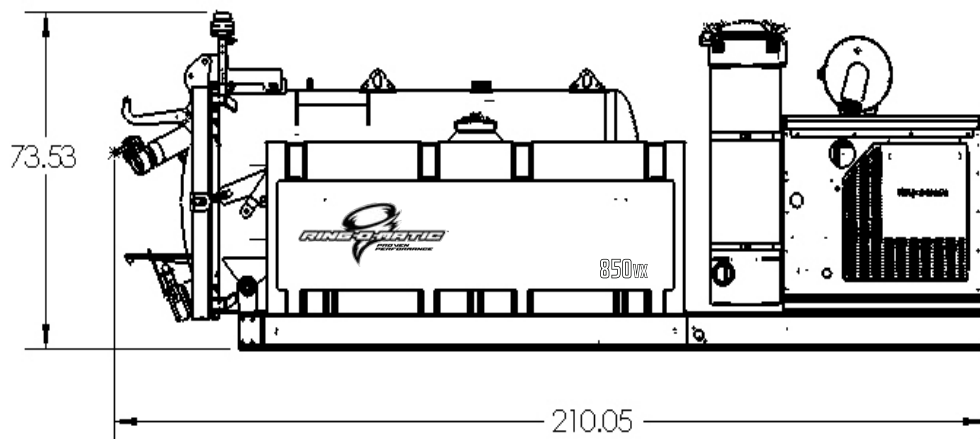

TRAILER DIMENSIONS

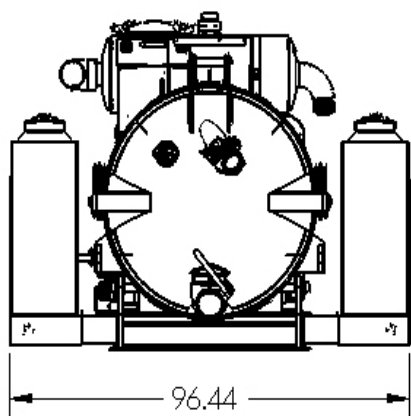
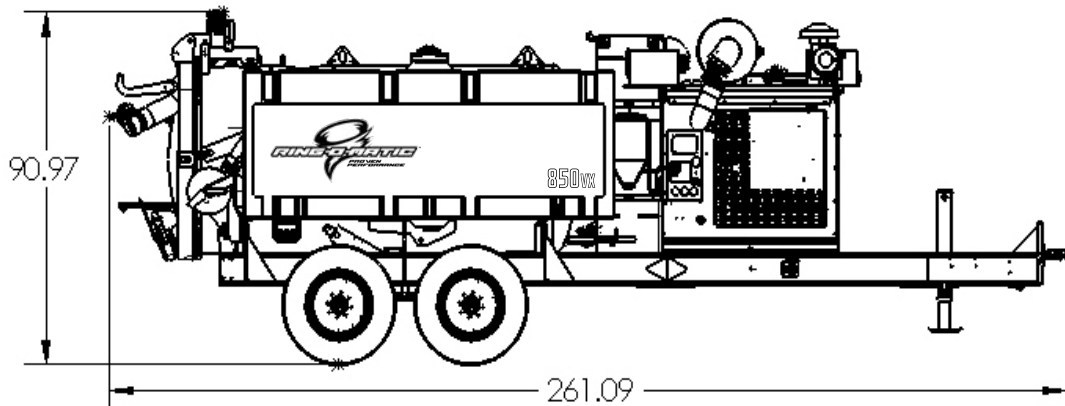
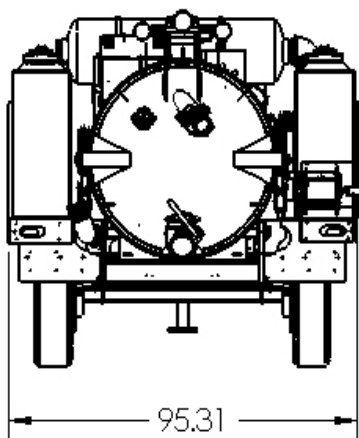

ALL MEASUREMENTS ARE GIVEN IN INCHES



FOR ALL TRUCK MOUNT
SPECIFICATIONS PLEASE
CONTACT OUR SALES
DEPARTMENT @
800-544-2518



1714 FIFIELD ROAD
PELLA, IOWA 50219

All equipment shown is for illustrative purposes only and may display optional accessories or components. Please contact your local Ring-O-Matic dealer or Corporate sales team for more information about machine specifications. Ring-O-Matic reserves the right to make changes in engineering, design and specifications; add improvements; or discontinue manufacturing at any time without notice or obligation. RING-O-MATIC, RING-O-MATIC Corporate logo, Ring-O-Matic Company R logo, PROVEN PERFORMANCE, VIPER, VIPER Tool Design, 850 VX and HiCFM are trademarks of Ring-O-Matic, INC. in the U.S. and / or other countries.



850 VX

from the innovator of vacuum excavation



RING-O-MATIC.COM

850 VX



FEATURES	850VX
Mountings	Trailer, truck & skid mounting
Spoils Capacity	800 gallons / 3,028 liters
Water Capacity (gallons / liters)	2 x 250 gallons / 2 x 946 liters
Optimum & Balanced Tongue Weight	Less than 1,200 lbs tongue weight
Engine	Tier 4F Industrial Diesel
Fuel Tank Capacity (gallons / liters)	29 gallons / 110 liters
Dual LED work lights and strobe	Standard
Warranty	One Year

OPERATOR CONTROLS	
Controls Location	Front curbside with lockable cabinet
Hour Meter / Tachometer / Vacuum Gauge	Standard
Water Supply Reel	Rear Curbside
Load Level Indicator and Auto Shutoff	Sight Glass & Auto Shutoff
Reverse Flow	Standard

SPOILS TANK DETAILS	
Hydraulic Hoist Unload	Twin cylinder
Full Opening Rear Door	Hydraulically operated
Rear Door Latch	Power door lock
Inlet Valve Size / Drain Valve Size	4" / 6"

TRAILER / SKID DETAILS - 8" C-CHANNEL FRAME	
Trailer / Hitch Type	Tandem Axle / Pintle
Trailer - Height / Length / Width (ft/in) / (m)	91" x 22'1" x 95" / (2.3 x 6.7 x 2.4)
Trailer - Empty Weight (lbs / kg)	7,540 lbs / 3420 kg
Gross Vehicle Weight Rating (lbs / kg)	16,000 lbs / 7258 kg
Axles, Capacity and Suspension Type	2 x 10,000 lbs Torsion
Tire Size	235/75 R 17.5 Load Range H
Trailer Brakes	Never adjust electric
Skid Mount - Height / Length / Width (ft/in) / (m)	74" x 17'6" x 96" / (1.8 x 5.3 x 2.4)
Skid Mount - Empty Weight (lbs / kg)	6,200 lbs / 2812 kg

VACUUM PUMP / BLOWER DETAILS	
Vacuum Pump / Blower Type	Positive displacement lobe pump
CFM/ Max Hg - 850 VX Standard	600 CFM / 15" / Roots Blower
CFM/ Max Hg - 850 VX HiCFM	1,000 CFM / 15" / Roots Blower
Reverse Flow	Standard
Cyclo-Separator Air Filter Type / Capacity	Cyclo-Separator with 4: 5 micron filters with 16,750 sq in capacity

WATER SYSTEM DETAILS	
Water Pressure / Water Supply	4,000 psi *factory set @ 3,500 psi / 6 gpm
Electronic Low Water Shut-Off	Standard
Auto Water Pump Unloader to Reduce Engine Loading & Wear	Standard
Water Pump Drive	Belt w/ Electric Clutch
Water Supply Hose	50' x 3/8" ID
Water Supply Reel Location	Rear curbside
Easy-to-Use Winterize System	Standard

OPTIONS	
Patented Viper Pothole Tool – DiElectric	Recommended
Curbside Remote Auxiliary Hydraulics	Optional
Full Hydraulic Controlled Boom or Manual Boom	Optional
Lighted Arrow Bar to Direct Traffic	Optional
Removable Water Heater	Optional
4" Vac Hose	Optional
In Tank Clean Out System	Optional
Sewer Jetter	Optional

KEY FEATURES

WATERTANKS



THE 850 VX HOLDS 2 X 250 GALLON (946 LITERS) FRESH WATER TANKS. BY REDUCING YOUR TIME OFF OF THE JOB SITE, YOU CAN INCREASE PRODUCTIVITY WITH 500-GALLON CAPACITY.

REVERSE FLOW

THE 850 VX OFFERS REVERSE FLOW STANDARD, WHICH ALLOWS YOU TO PRESSURIZE THE TANK FOR EASY OFFLOADING AND ASSISTS IN CLEARING HOSE OBSTRUCTIONS.



FILTRATION



WITH THE HIGHEST FILTRATION RATE ON THE MARKET, THE 850 VX OFFERS CUSTOMERS THE PEACE OF MIND THAT OUR FILTRATION SYSTEM OFFERS SUPERIOR AIR FILTRATION TO THE BLOWER.

AXLES

THE 850 VX OFFERS 2 X 10000 LBS AXLES TO GIVE THE MACHINE ULTIMATE STABILITY AND HANDLING IN THE WORK SITE AND ON THE ROAD.



WATER PUMP



WITH THE HIGHEST RATED WATER PUMP ON THE MARKET AT 6.0 GPM / 3500 PSI THE 850 VX WILL LET YOU DIG FASTER AND EASIER IN ANY TYPE OF SOIL.



CLEANEST. SAFEST. FASTEST. EASIEST. ONE MAN POTHOLING SOLUTION.

ONLY AVAILABLE FROM RING-O-MATIC, THE PATENTED VIPER POT HOLE TOOL DELIVERS UNMATCHED PERFORMANCE ON THE JOBSITE. THE VIPER DELIVERS INCREASED PROFITABILITY AND PRODUCTIVITY FOR CONTRACTORS, MUNICIPALITIES, OWNERS/ OPERATORS, AND RENTAL OPERATIONS. CONCERNED ABOUT JOB SITE SAFETY? THE VIPER COMES IN OUR STANDARD DIELECTRIC OPTION - PROVIDING SAFE EXPOSURE/DAYLIGHTING OF UTILITIES AND IN OPERATOR SAFETY VIA THE DIELECTRIC FITTING. THERE'S NO OTHER TOOL LIKE IT ON THE MARKET.

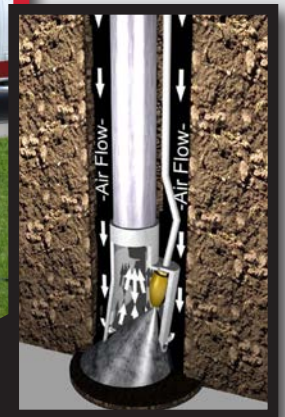

800.544.2518